

PART NUMBER 3261

SAE 5 BOLT TO 1¼" BSP SENDER MOUNTING RING INSTALLATION INSTRUCTIONS

This component is designed to allow a Tank Sender with a 1¼" BSP threaded mount to fit a SAE 5 bolt hole pattern in the tank top.

It comes with both an EPDM gasket suitable for water tanks and a nitrile/cork bonded gasket suitable for fuel tanks. It is important to select the correct gasket to match the tank's contents.

The ring should be attached to the top of the tank and the gasket by using 5 x 4mm diameter countersunk machine screws with washers and nuts inside the tank.

DANGER! After installation always check that the ring has sealed to the tank and that there are no fuel or water leaks.

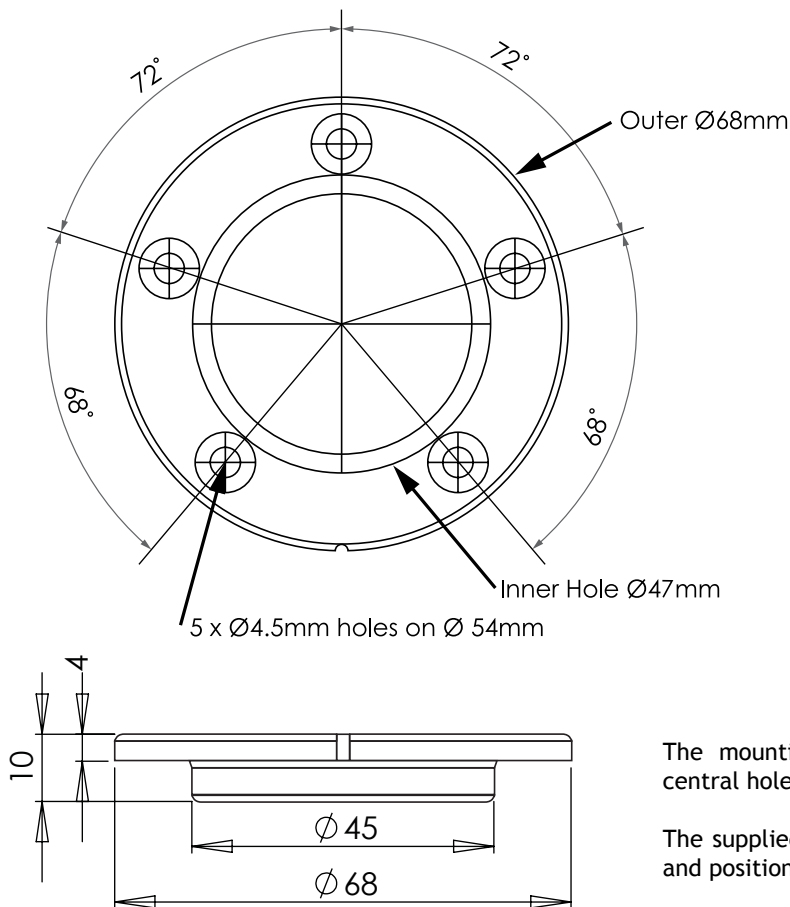

The mounting diagram shows the mounting hole and central hole locations and sizes.

The supplied gaskets can be used to mark the hole sizes and positions if desired.